

— PROPRIETARY —  
 THIS DOCUMENT CONTAINS CONFIDENTIAL, PROPRIETARY INFORMATION  
 THAT IS FOX PROPERTY. DO NOT DISCLOSE TO OR DUPLICATE  
 FOR OTHERS EXCEPT AS AUTHORIZED BY FOX.

REVISIONS					
ZONE	REV	DESCRIPTION	DATE	BY	CHECKED
	A	INITIAL RELEASE	2021-11-10	DAC	DRB

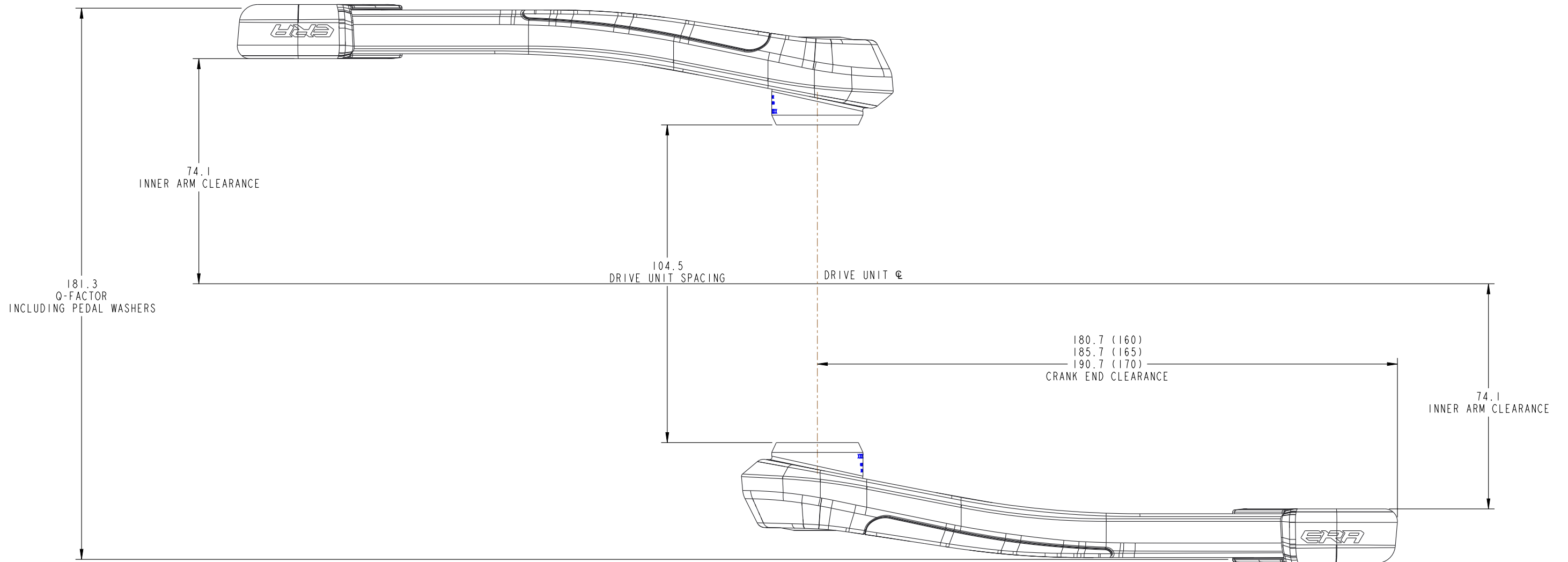
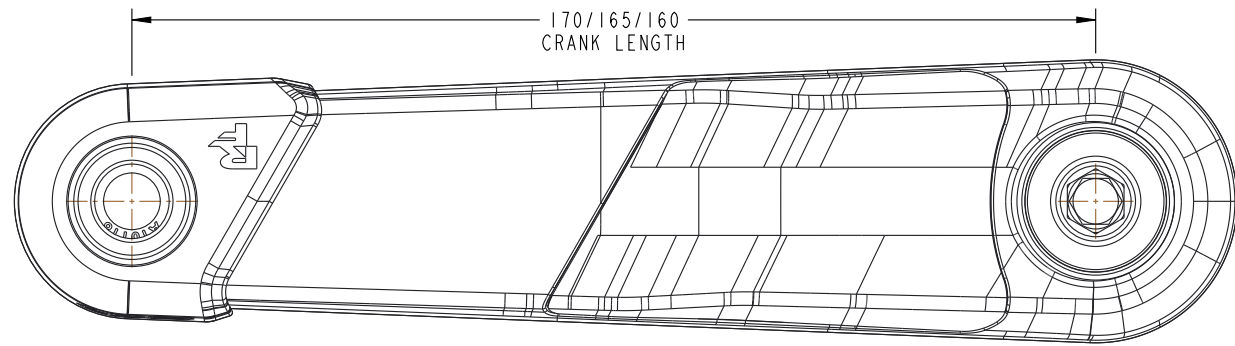

UNLESS OTHERWISE SPECIFIED,  
 ALL DIMENSIONS ARE IN mm

PER ASME Y14.5-2018



**FOX FACTORY INC.**  
 SPECIALTY SPORTS GROUP  
 \*118 - 8333 EASTLAKE DRIVE  
 BURNABY BC, V5A 4W2

APPROVALS		DATE
DWN. BY	DAC	2021-11-10
CHK. BY	DRB	2021-11-12
ENG.	DAC	2021-11-10
MFG.		
ADD.		

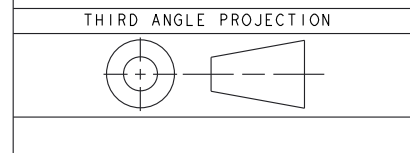

<b>CRANKARMS, ERA-E, BG4</b>		
SIZE	PART NO.	REVISION
B	OCK23ERAEXXXXXX-CUST	A
PLOT SCALE 3:4		SHEET 1 OF 2

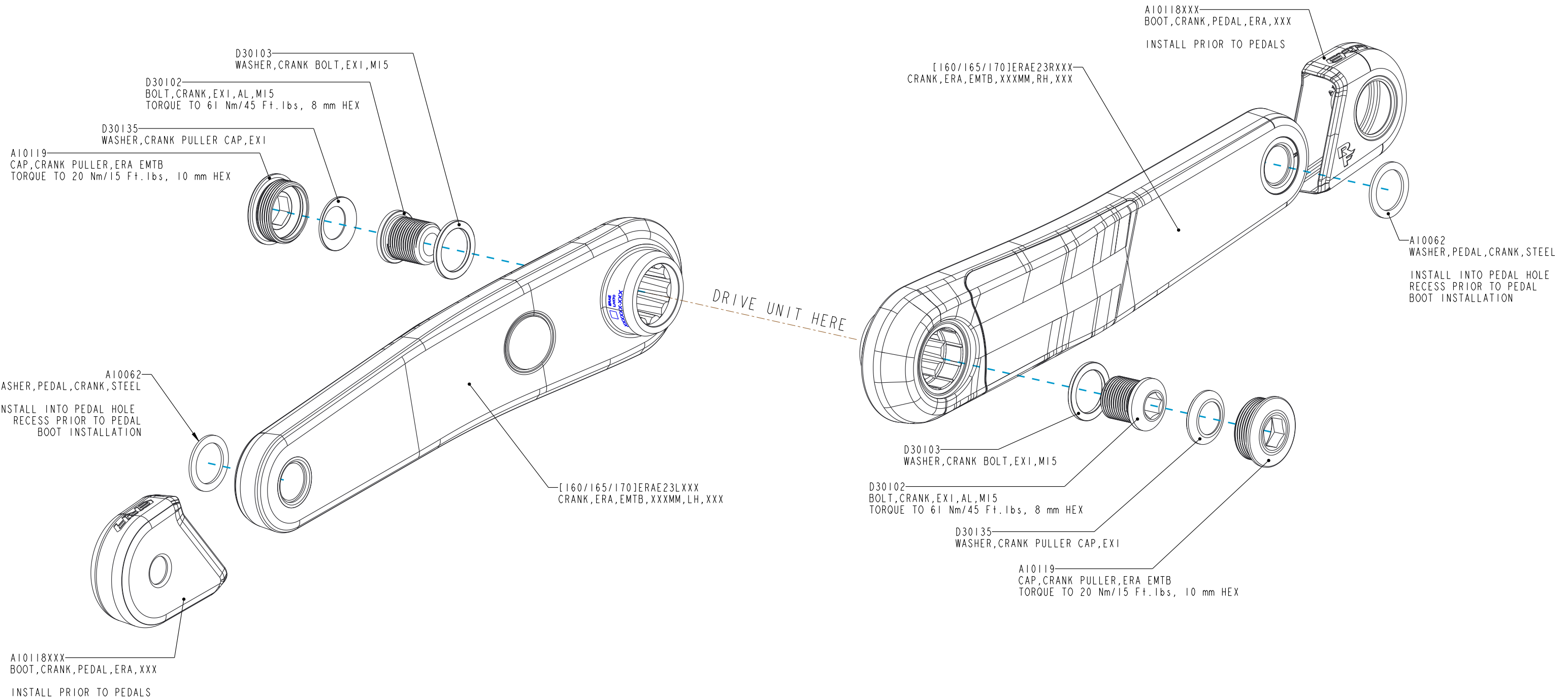

— PROPRIETARY —  
 THIS DOCUMENT CONTAINS CONFIDENTIAL, PROPRIETARY INFORMATION  
 THAT IS FOX PROPERTY. DO NOT DISCLOSE TO OR DUPLICATE  
 FOR OTHERS EXCEPT AS AUTHORIZED BY FOX.

SIZE B	CAGE NO. NONE	DWG. NO. OCK23ERAEXXXXXX-CUST	REV. A
PLOT SCALE 3:4		2 OF 2	